

# ROADTHUNDER®

## Wiring Configuration

La Configuración del alambrado, La Configuración del alambrado, Verdrahtende Konfiguration

### RTS10-04



# ROADTHUNDER®

### RTS10-04

## Parameters

Los parámetros, Paramètres, Parameter

- Fs: **34.88 Hz**
- Qms: **5.11**
- Cms: **0.172 mm/N**
- Mms: **120.9 g**
- Rms: **5.192 kg/s**
- Vas: **1.127 ft<sup>3</sup> (31.9 liters)**
- Xmax: **0.42 in (10.67 mm)**
- D: **8.465 in (215 mm)**
- Sd: **56.27 in<sup>2</sup> (363 cm<sup>2</sup>)**
- Vd: **25.89 in<sup>3</sup> (0.437 liters)**
- Qes: **0.71**
- Re: **3.95 Ω**
- Bl: **12.18 Tm**
- Prms: **250 Watts**
- Qts: **0.62**
- η<sub>0</sub>: **0.18%**
- SPL<sub>0</sub>: **84.7 dB**
- SPL 2.83V/1m: **87.8 dB**

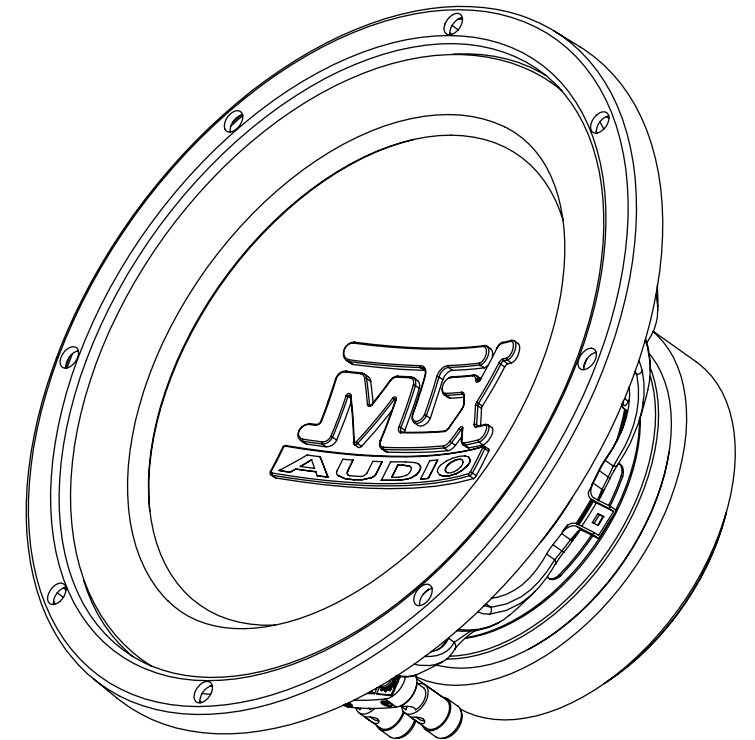

## Specifications

Las especificaciones, Specifications, Spezifikationen

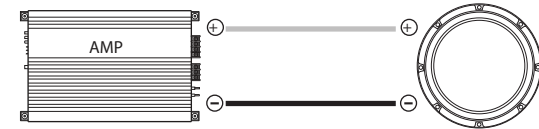

**Wired Direct** (Alambró Directo, Télégraphié Direct, Direkt hat verdrahtet)

**A 4Ω speaker will represent a 4Ω load.**

(Un orador 4Ω representará una carga 4Ω, Un 4Ω haut-parleur représentera un 4Ω chargent, Ein 4Ω Sprecher beladen eine 4Ω wird vertreten)

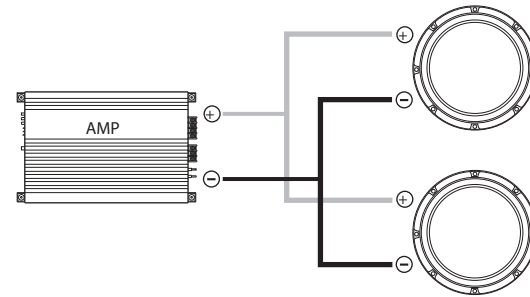

**Two Speakers wired in parallel** (Dos Oradores alambraron en la paralela, Deux Haut-parleurs ont télégraphié dans l'analogie, Zwei Sprecher haben parallel verdrahtet):

**A 4Ω speaker will represent a 2Ω load.**

(Un orador 4Ω representará una carga 2Ω, Un 4Ω haut-parleur représentera un 2Ω chargent, Ein 4Ω Sprecher beladen eine 2Ω wird vertreten)

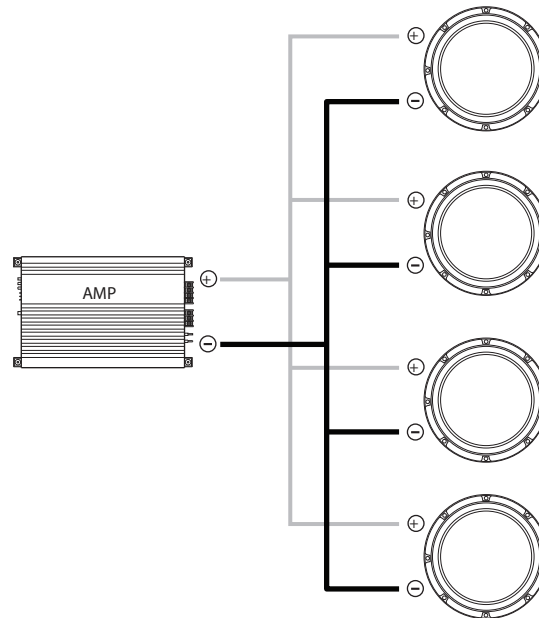

**Four Speakers wired in parallel** (Cuatro Oradores alambraron en la paralela, Quatre Haut-parleurs ont télégraphié dans l'analogie, Vier Sprecher haben parallel verdrahtet):

**A 4Ω speaker will represent a 1Ω load.**

(Un orador 4Ω representará una carga 1Ω, Un 4Ω haut-parleur représentera un 1Ω chargent, Ein 4Ω Sprecher beladen eine 1Ω wird vertreten)

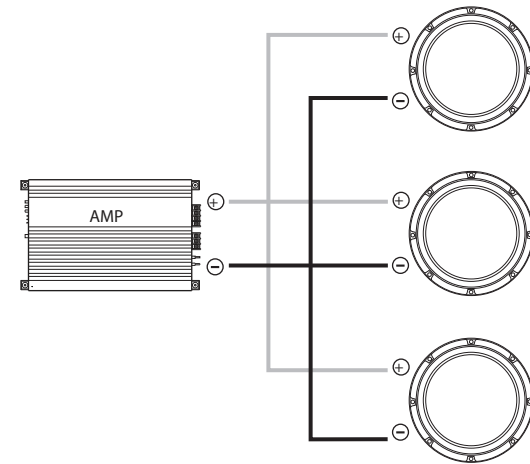

**Three Speakers wired in parallel** (Tres Oradores alambraron en la paralela, Trois Haut-parleurs ont télégraphié dans l'analogie, Drei Sprecher haben parallel verdrahtet):

**A 4Ω speaker will represent a 1.3Ω load.**

(Un orador 4Ω representará una carga 1.3Ω, Un 4Ω haut-parleur représentera un 1.3Ω chargent, Ein 4Ω Sprecher beladen eine 1.3Ω wird vertreten)

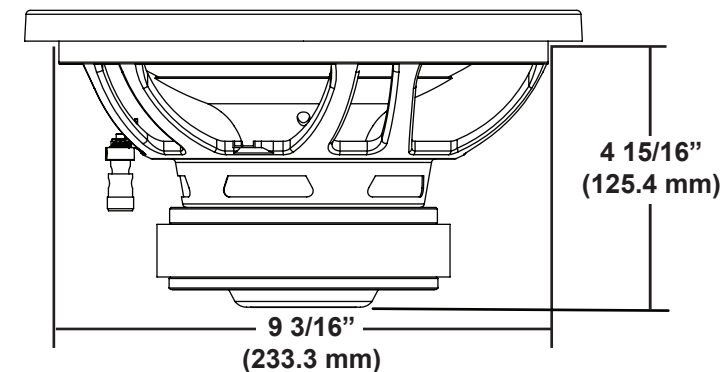
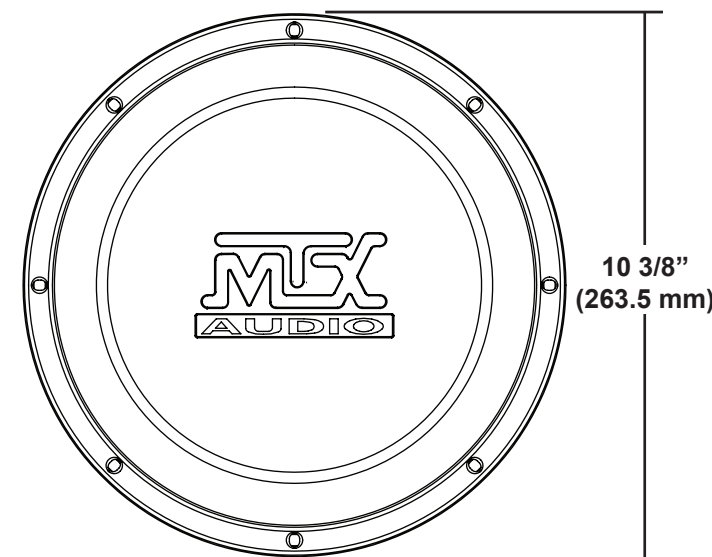

## Recommended Power Rating of 125 - 250 Watts RMS

La Potencia nominal recomendada, Le Pouvoir recommandé Evaluant, Empfohlene Kraft Einzuschätze

# ROADTHUNDER®

## Sealed Enclosure

*El Cerco sellado, Cloture scellée, Abgedichtete Einschließung*

For the best possible sound quality where space is a premium, MTX recommends using a sealed enclosure. For excellent sound quality with increased output compared to sealed enclosures (3dB or more), MTX recommends using a vented enclosure. All recommended enclosures have been designed and thoroughly tested by MTX.

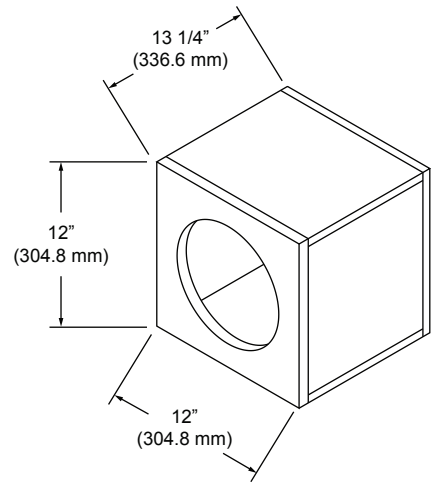

# RTS10-04

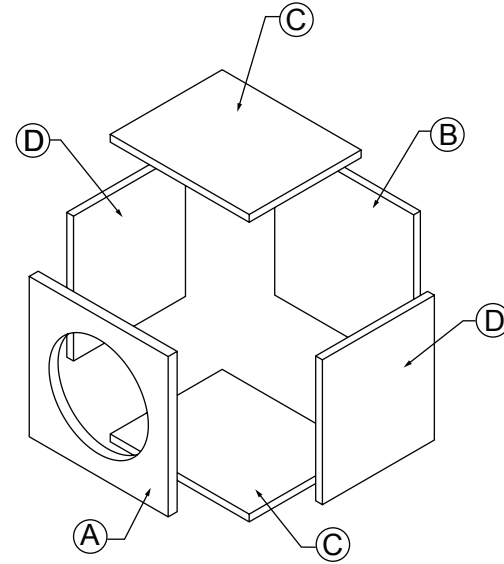

Net Internal Volume: 0.75 ft<sup>3</sup>

## Parts List

*La Lisat de partes, Liste de parties, Ersatzteilliste*

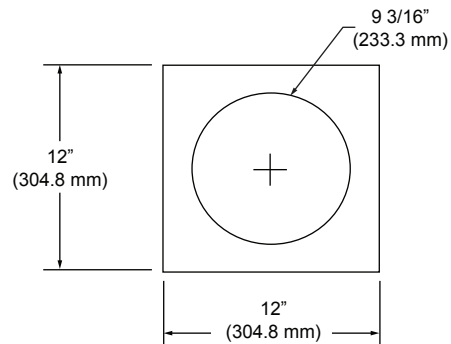

[A] - 3/4" (19 mm) MDF

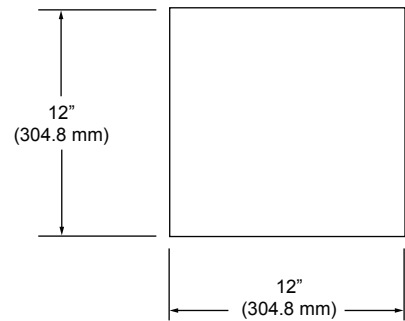

[B] - 3/4" (19 mm) MDF

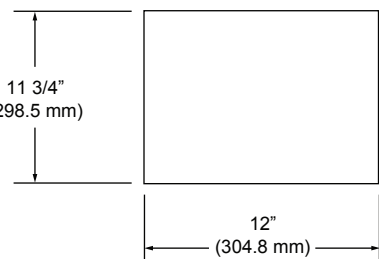

[C] - 3/4" (19 mm) MDF

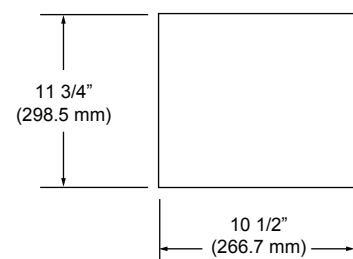

[D] - 3/4" (19 mm) MDF

# ROADTHUNDER®

## Vented Enclosure

*Descargar Cerco, Clôtüre donnere vent, Vented Einschließung*

For the best possible sound quality where space is a premium, MTX recommends using a sealed enclosure. For excellent sound quality with increased output compared to sealed enclosures (3dB or more), MTX recommends using a vented enclosure. All recommended enclosures have been designed and thoroughly tested by MTX.

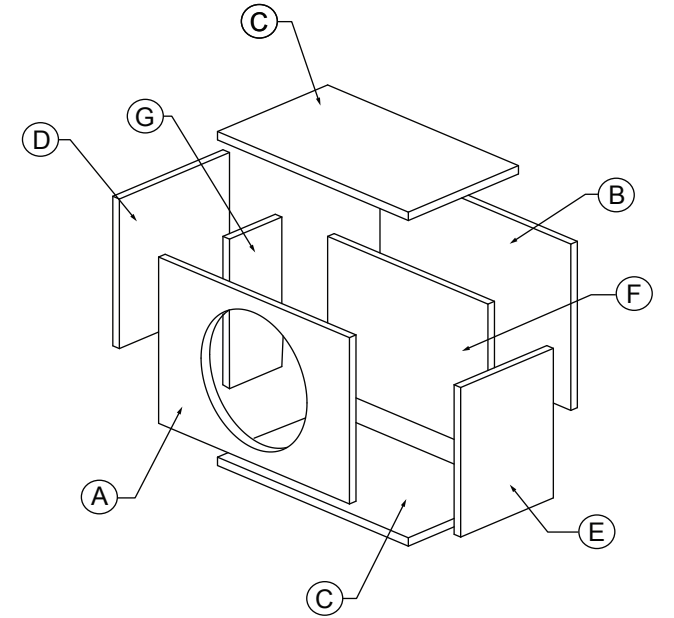
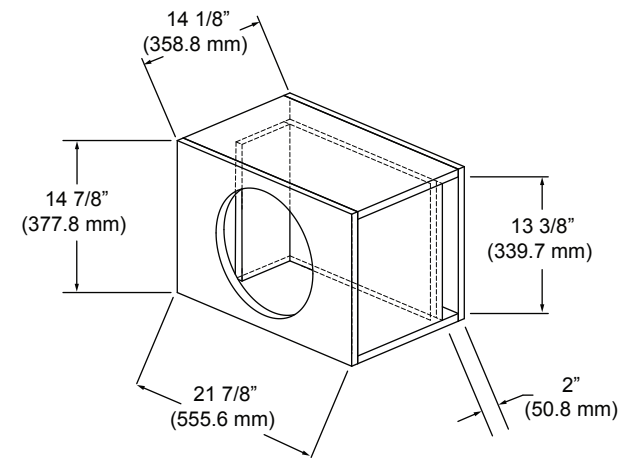

Net Internal Volume: 2.00 ft<sup>3</sup>

## Parts List

*La Lisat de partes, Liste de parties, Ersatzteilliste*

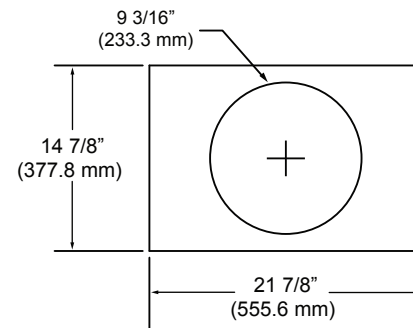

[A] - 3/4" (19 mm) MDF

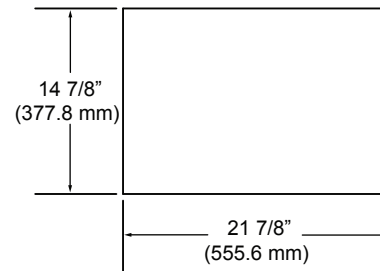

[B] - 3/4" (19 mm) MDF

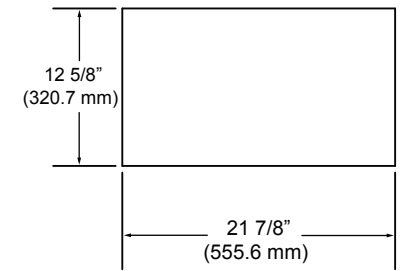

[C] - 3/4" (19 mm) MDF

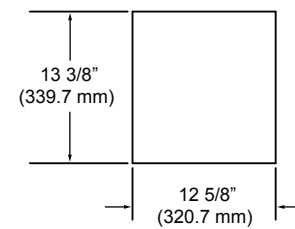

[D] - 3/4" (19 mm) MDF

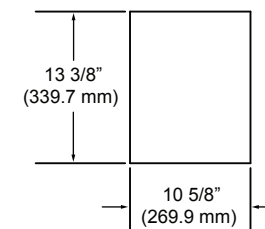

[E] - 3/4" (19 mm) MDF

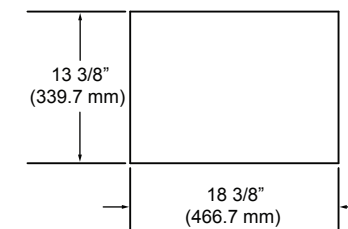

[F] - 3/4" (19 mm) MDF

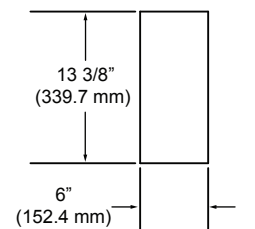

[G] - 3/4" (19 mm) MDF